











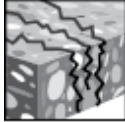

HKD Push-in anchor, redundant fastening

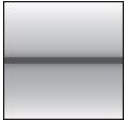
Anchor version		Benefits
	HKD (M6-M16)	<ul style="list-style-type: none"> - Simple and well proven - Approved, tested and confirmed by everyday jobsite experience - Reliable setting thanks to simple visual check - Versatile - For medium-duty fastening with bolts or threaded rods - Available in various materials and sizes for maximized coverage of possible applications
	HKD-woL (M6-M16)	
	HKD-S(R) (M6-M12)	
	HKD-E(R) (M6-M12)	

Base material			Load conditions		
					
Concrete (non-cracked)	Concrete (cracked)	Redundant fastening	Static/ quasi-static	Fire resistance	

Other information			
			
European Technical Assessment	CE conformity	Sprinkler approved	Corrosion resistance

Approvals / certificates

Description	Authority / Laboratory	No. / date of issue
European Technical Assessment ^{a)}	DIBt, Berlin	ETA-06/0047 / 2016-02-08
Fire test report	DIBt, Berlin	ETA-06/0047 / 2016-02-08
Assessment report fire	Warringtonfire	WF 327804/A / 2013-07-10

a) All data given in this section according to ETA-06/0047, issue 2016-02-08.

Static and quasi-static resistance for

All data in this section applies to:

- Correct setting (See setting instruction)
- No edge distance and spacing influence
- Minimum base material thickness
- Concrete C 20/25, $f_{ck,cube} = 25 \text{ N/mm}^2$
- Anchors in redundant fastening

Effective anchorage depth for static

Anchor size	M6	M6	M8	M8	M8	M10	M10	M10	M12	M12	M16
Eff. anchorage depth range h_{ef} [mm]	25	30	25	30	40	25	30	40	25	50	65

Characteristic resistance, all load directions

Anchor size			M6x25	M6x30	M8x25	M8x30	M8x40	M10x25	M10x30	M10x40	M12x25	M12x50	M16x65
Load F_{Rk}	HKD / HKD-woL	[kN]	2,0	-	3,0	5,0	5,0	4,0	5,0	7,5	4,0	9,0	16,0
	HKD-S/ HKD-E		-	3,0	-	3,0	5,0	-	4,0	6,0	-	6,0	-
	HKD-SR/ HKD-ER		-	3,0	-	3,0	-	-	-	6,0	-	6,0	-

Design resistance, all load directions

Anchor size			M6x25	M6x30	M8x25	M8x30	M8x40	M10x25	M10x30	M10x40	M12x25	M12x50	M16x65
Load F_{Rd}	HKV / HKD-woL	[kN]	1,3	-	2,0	2,8	3,3	2,2	3,3	5,0	2,7	6,0	10,7
	HKD-S/ HKD-E		-	2,0	-	2,0	3,3	-	2,7	4,0	-	4,0	-
	HKD-SR/ HKD-ER		-	2,0	-	2,0	-	-	-	4,0	-	4,0	-

Recommended loads ^{a)}, all load directions

Anchor size			M6x25	M6x30	M8x25	M8x30	M8x40	M10x25	M10x30	M10x40	M12x25	M12x50	M16x65
Load F_{Rec}	HKV / HKD-woL	[kN]	1,0	-	1,4	2,0	2,4	1,6	2,4	3,6	1,9	4,3	7,6
	HKD-S/ HKD-E		-	1,4	-	1,4	2,4	-	1,9	2,9	-	2,9	-
	HKD-SR/ HKD-ER		-	1,4	-	1,4	-	-	-	2,9	-	2,9	-

- a) With overall partial safety factor for action $\gamma = 1,4$. The partial safety factors for action depend on the type of loading and shall be taken from national regulations.

Requirements for redundant fastening

The definition of redundant fastening according to Member States is given in the ETAG 001 Part six, Annex 1. In Absence of a definition by a Member State the following default values may be taken.

Minimum number of fixing points	Minimum number of anchors per fixing point	Maximum design load of action N_{Sd} per fixing point ^{a)}
3	1	2 kN
4	1	3kN

- a) The value for maximum design load of actions per fastening point N_{Sd} is valid in general that means all fastening points are considered in the design of the redundant structural system. The value N_{Sd} may be increased if the failure of one (=most unfavorable) fixing point is taken into account in the design (serviceability and ultimate limit state) of the structural system e.g. suspended ceiling.

Materials

Mechanical properties

Anchor size			M6	M8	M10	M10	M12
Nominal tensile strength	f_{uk}	HKV / HKD-woL	570	570	570	570	640
		HKD-S, HKD-E	560	560	510	510	-
		HKD-SR, HKD-ER	540	540	540	540	-Ö
Yield strength	f_{yk}	HKV / HKD-woL	460	460	460	480	510
		HKD-S, HKD-E	440	440	410	410	-
		HKD-SR, HKD-ER	355	355	355	355	-
Stressed cross-section	A_s	HKV / HKD-woL	20,7	26,7	32,7	60,1	105
		HKD-S, HKD-E	20,9	26,1	28,8	58,7	-
		HKD-SR, HKD-ER					
Moment of resistance	W	HKV / HKD-woL	32,3	54,6	82,9	184	431
		HKD-S, HKD-E	50	79	110	264	-
		HKD-SR, HKD-ER					
Char. bending resistance for rod or bolt	$M^0_{Rk,s}$	With 5.8 Gr. Steel	7,6	18,7	37,4	65,5	167
		HKD-SR	11	26	52	92	-
		HKD-ER with A4-70					

Material quality

Part		Material
Anchor body	HKV / HKD-woL	Cold formed steel-galvanized to $\geq 5 \mu\text{m}$
	HKD-S, HKD-E	Steel Fe/Zn5, galvanized to $\geq 5 \mu\text{m}$
	HKD-SR, HKD-ER	Stainless steel, 1.4401, 1.4404, 1.4571 EN 10088-3:2014
Expansion plug	HKV / HKD-woL	Cold formed steel
	HKD-S, HKD-E	Cold formed steel
	HKD-SR, HKD-ER	Stainless steel, 1.4401, 1.4404, 1.4571 EN 10088-3:2014

Anchor dimensions of HKD, HKD-S, HKD-E, HKD-SR, HKD-ER

Anchor size		M6x25	M8x25	M10x25	M12x25	M6x30	M8x30	M8x40	M10x30	M10x40	M12x50	M16x65
Anchor length	l_G [mm]	25	30	25	30	40	25	30	40	25	50	65
Anchor diameter	\varnothing_{d1} [mm]	7,9	8	9,95	9,95	9,95	11,9	11,8	11,95	14,9	14,9	19,75
Plug diameter	\varnothing_{d2} [mm]	5,1	5	6,35	6,5	6,35	8,1	8,2	8,2	9,7	10,3	13,8
Plug length	l_1 [mm]	10	15	7	12	16	7	12	16	7,2	20	29

Anchor body

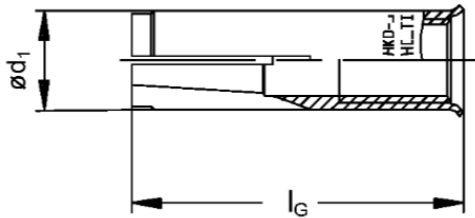

Expansions plugs

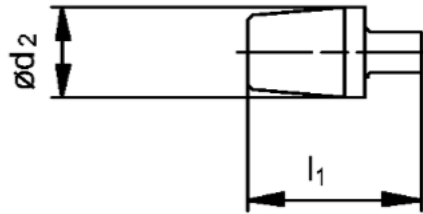

Setting information

Setting details

Anchor size		M6x25	M6x30	M8x25 ^{a)}	M8x30	M8x40	M10x25 ^{a)}	M10x30 ^{a)}	M10x40	M12x25 ^{a)}	M12x50	M16x65
Effective anchorage depth	h_{ef} [mm]	25	30	25	30	40	25	30	40	25	50	65
Nominal diameter of drill bit	d_0 [mm]	8	8	10	10	10	12	12	12	15	15	20
Thread diameter	d [mm]	6	6	8	8	8	10	10	10	12	12	16
Depth of drill hole	h_1 [mm]	27	32	27	33	43	27	33	43	27	54	70
Diameter of clearance hole in the fixture	d_f [mm]	7	7	9	9	9	12	12	12	14	14	18
Torque moment	T_{inst} [mm]	4	4	8	8	8	15	15	15	35	35	60
Screwing depth	$l_{s,min}$ [mm]	6	6	8	8	8	10	10	10	12	12	16
	$l_{s,max}$ [mm]	12	12,5	11,5	14,5	17,5	12	12,7	18	12	23,5	30,5

a) With anchor size M8x25, M10x25, M10x30 and M12x25 only threaded rod are to be used.

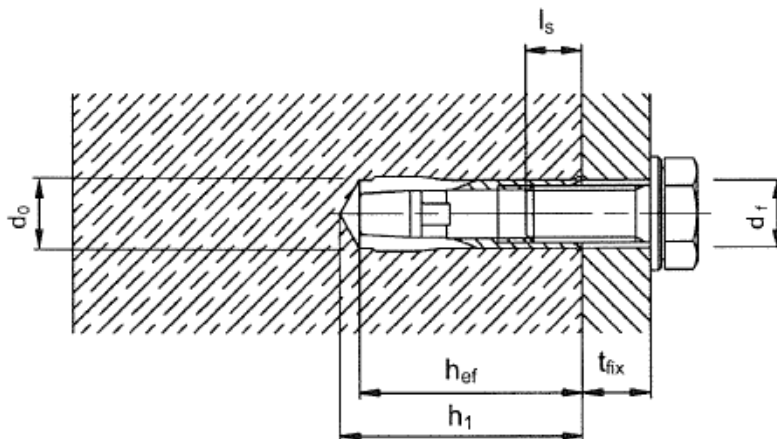

Installation equipment

Anchor size		M6x25	M8x25	M10x25	M12x25	M6x30	M8x30	M8x40	M10x30	M10x40	M12x50	M16x65
Rotary hammer for setting		TE 2 – TE 16									TE16–TE50	
Machine setting tool	HSD-M	6x25/30	8x25/30	8x40	10x25/30	10x40	12x25	12x50	16x65			
Hand setting tool	HSD-G											
Other tools		Hammer, torque wrench, blow out pump										

Setting parameters

Anchor size		M6x25	M6x30	M8x25 ^{a)}	M8x30	M8x40	M10x25 ^{a)}	M10x30 ^{a)}	M10x40	M12x25 ^{a)}	M12x50	M16x65
Minimum spacing and minimum edge distance for HKD / HKD-woL												
Minimum thickness of concrete member	h_{min} [mm]	100	-	100	100	100	100	100	100	100	100	120
Minimum spacing	s_{min} [mm]	80	-	80	60	80	80	60	80	80	125	130
	$c \geq$ [mm]	140	-	140	105	140	140	105	140	140	175	230
Minimum edge distance	c_{min} [mm]	100	-	100	80	140	100	80	140	100	175	230
	$s \geq$ [mm]	150	-	150	120	80	150	120	80	150	125	130
Minimum thickness of concrete member for HKD / HKD-woL												
Minimum thickness of concrete member	h_{min} [mm]	80	-	80	80	80	80	80	80	80	-	-
Minimum spacing	s_{min} [mm]	200	-	200	200	200	200	200	200	200	-	-
Minimum edge distance	c_{min} [mm]	150	-	150	150	150	150	150	150	150	-	-
Minimum spacing and minimum edge distance for HKD-S(R) / HKD-S(R)												
Minimum thickness of concrete member	h_{min} [mm]	-	100	-	100	100	-	100	100	-	100	-
Minimum spacing	s_{min} [mm]	-	60	-	60	80	-	60	80	-	125	-
Minimum edge distance	c_{min} [mm]	-	105	-	105	140	-	105	140	-	175	-
Minimum thickness of concrete member for HKD-S(R) / HKD-S(R)												
Minimum thickness of concrete member	h_{min} [mm]	-	80	-	80	80	-	80	80	-	-	-
Diameter of clearance hole in the fixture	s_{min} [mm]	-	200	-	200	200	-	200	200	-	-	-
Torque moment	c_{min} [mm]	-	150	-	150	150	-	150	150	-	-	-

For spacing (edge distance) smaller than critical spacing (critical edge distance) the design loads have to be reduced.

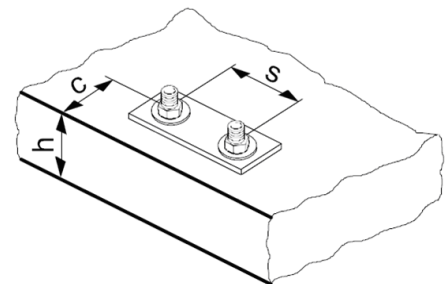

Setting instruction

*For detailed information on installation see instruction for use given with the package of the product.

Setting instruction	
<p>1. Drilling</p>	<p>2. Cleaning</p>
<p>3. Inserting the anchor</p>	<p>4. Setting tools</p> <p>HSD-G M8x30 </p> <p>HSD-M M8x30 </p>
<p>5. Inserting the tools</p>	<p>6. Inserting the tools</p>
<p>7. Attaching the belonging washer</p>	<p>8.</p>

Setting instruction with the stop drill bit TE-CX-HKD only

1. Positioning pre-stressed steel



2. Marking pre-stressed steel position

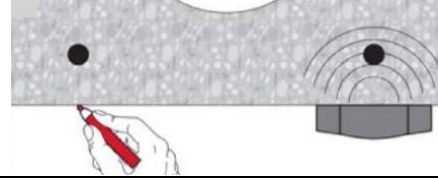

3. Marking pre-stressed steel position



4. Drilling

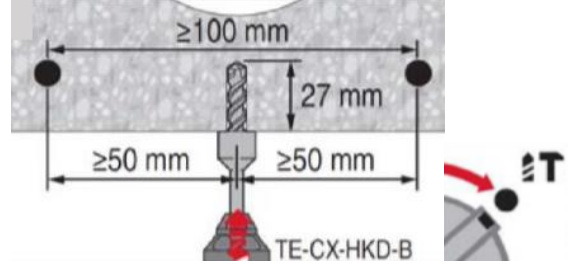

5. Cleaning

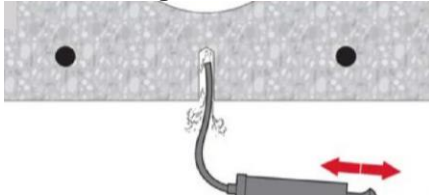

6. Inserting the anchor

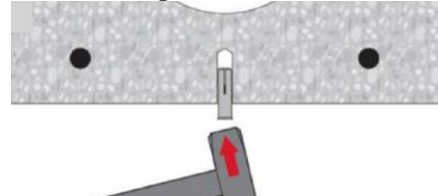

7. Setting tools

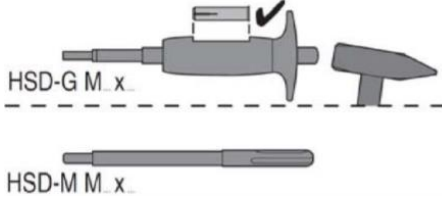

8. Inserting the tools

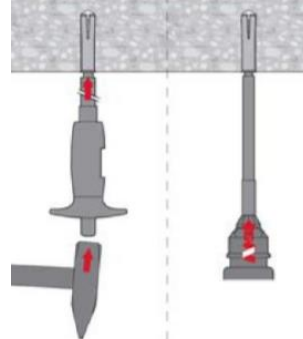

9. Inserting the tools

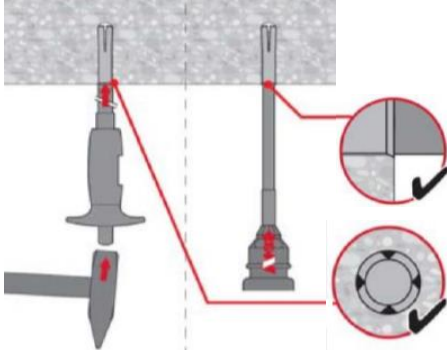

10. Attaching the belonging washer

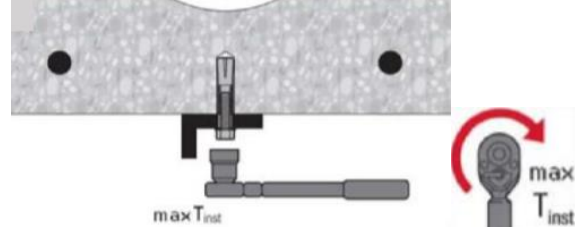

11.

